

Revision Level		Revision Record	Changed	Date	Approval	Date
Part	Drawing					
	①	Remove bundle diameter.	Mandy Ong	28-Jan-09	Edward Tan	28-Jan-09
	②	Added PA 46 material onto the drawing.	SIMON NG	27-Oct-16	Edward Tan	27-Oct-16
	③	Added HT Global project Number.	SIMON NG	10-Sep-19	Edward Tan	10-Sep-19
	④	Added cable tie dimensions chart.	SIMON NG	10-Sep-19	Edward Tan	10-Sep-19
	⑤	Remove tie head dimension.	SIMON NG	10-Sep-19	Edward Tan	10-Sep-19
	⑥	Rearrange dimension and product discription.	SIMON NG	10-Sep-19	Edward Tan	10-Sep-19

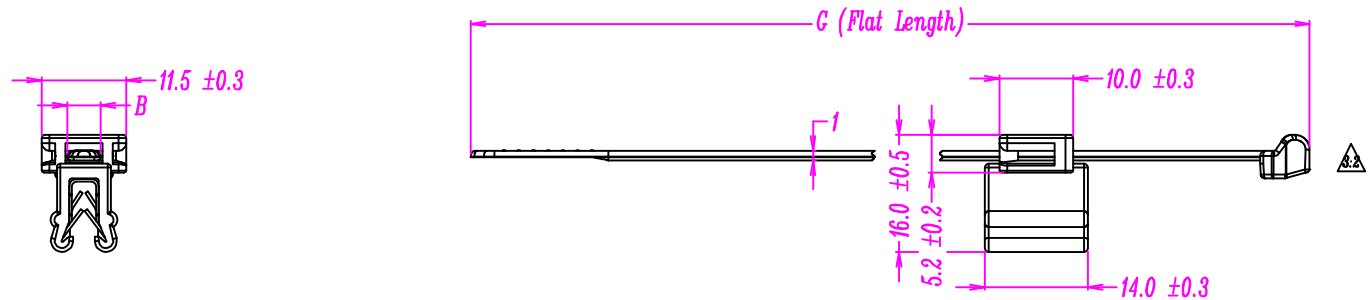

Delivery Conditions

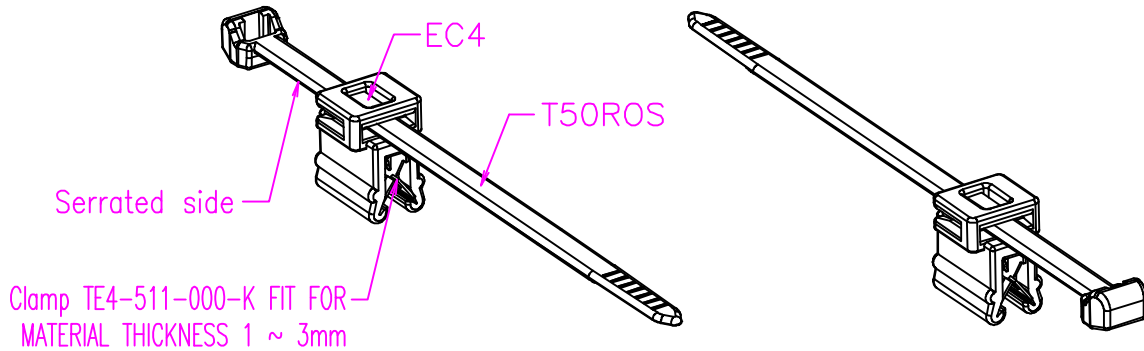

A	B	G
1.3 ± 0.2	4.6 ± 0.2	200.0 ± 5.0

Material
P.A. 66
② P.A. 46
Tensile strength
225N (Minimum)
PERFORMANCE SPECIFICATION

ACAD

The copyright of this drawing is reserved by HELLERMANN TYTON. It is issued on condition that it is not reproduced, copied or disclosed to a third party, either wholly or in part, without the consent of HELLERMANN TYTON.

Drawn WENDY TAN 08 April 2008
 Approved. EDWARD TAN 08 April 2008

HellermannTyton

545, Yishun Industrial Park A
 Yishun Avenue 7
 Singapore 768741
 Tel: (+65) 6852 8585
 Fax: (+65) 6756 6798

Scale: 1 : 1 Reference: 14.1501

Title T50ROSEC4B

Drawing-No [SG08009-03]

99-0760-050-CSH ③

Format A4 Sheet 1 of 1

Uncontrolled Document